

MMA701-SOT89

High Linearity Packaged HBT

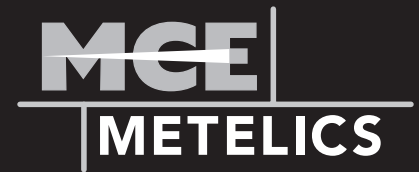

FEATURES

- +45 dBm IP3 at 2.1 GHz
- +25 dBm Output Power at P-1 dB Compression
- 50% Power added efficiency (typical)
- 100 MHz to 4000 MHz Operation

The MMA701 is an InGaP Heterojunction Bipolar Transistor (HBT) amplifier in a low cost SOT-89 surface mount package. The MMA701 will produce +45 dBm OIP3 at the minimum bias voltage. The combination of low noise figure and high intercept point make it ideal for transmitter and receiver applications.

The MMA is ideally suited for Cellular/PCS, 2.5/3G, WLL and MMDS systems and other types of Wireless applications where high gain, P1dB, OIP3, and convenient power down is required. Custom packages and Die options are available. Consult the factory for details.

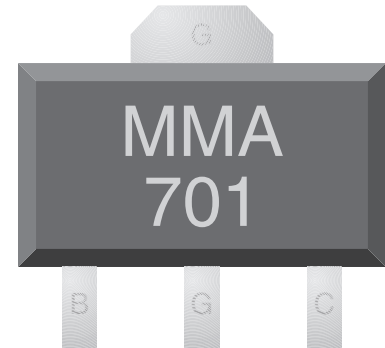

Application notes are available at www.metelics.com.

ELECTRICAL SPECIFICATIONS

Parameter	Symbol	Test Conditions	Minimum @ +5 VDC	Typical @ +5 VDC	Typical @ +7 VDC	Maximum	Units
Gain	SSG	icc = 130 ma	11.5	12.2	12.2		dB
Output Power	P-1dB	icc = 130 ma	+24.5	+25	+27		dBm
Intercept	OIP3	icc = 130 ma	+42	+45	+47		dBm
ACPR (W-CDMA)	ACPR	icc = 130 ma +17 dbm output 5 MHz offset		-59	-65		dB
Noise Figure	NF	icc = 130 ma		3	3.5		dB

1. T = 25° C, Frequency: 2140 MHz, matched to 50 ohm system
2. OIP3 measured with two tones at an output power of +12 dBm/tone. Tone separation of 1.2288 MHz.

ABSOLUTE MAXIMUM RATINGS

Parameter	Rating
Operating Case Temperature	-40°C to +85°C
Storage Temperature	-40°C to +125°C
Junction Temperature	+230°C
Thermal Resistance	70°C/W
Supply Voltage, Vceo	+10 V
Input RF Power (continuous)	+18 dBm

Operation of this device above any of these parameters may cause permanent damage.



975 Stewart Drive • Sunnyvale, CA 94085 • www.metelics.com
 PH 408.737.8181 • FX 408.733.7645 • sales@metelics.com

© Copyright 2001 MCE Metelics. All rights reserved. Specifications subject to change without notice. Revision date 09.15.01.

MMA701-SOT89

High Linearity Packaged HBT



SWEPT DATA

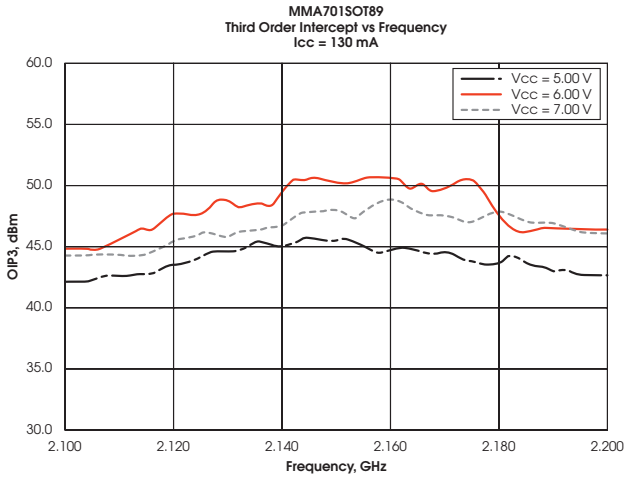

POWER GAIN AND OUTPUT POWER VS INPUT POWER

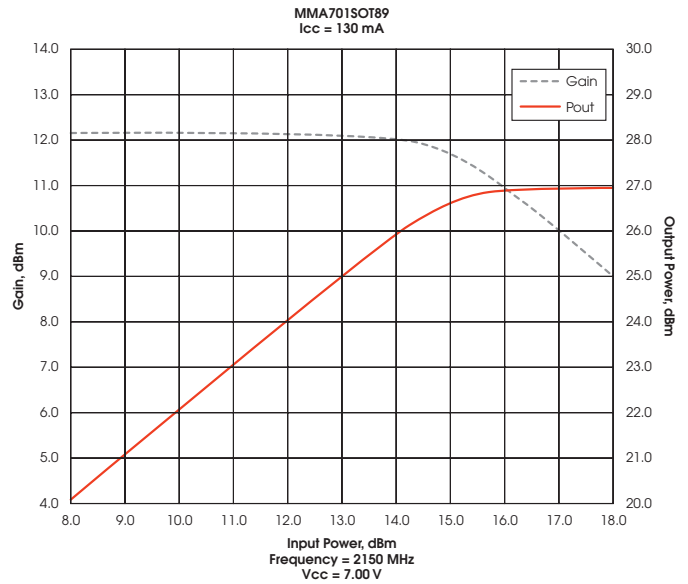

W-CDMA ACPR PERFORMANCE

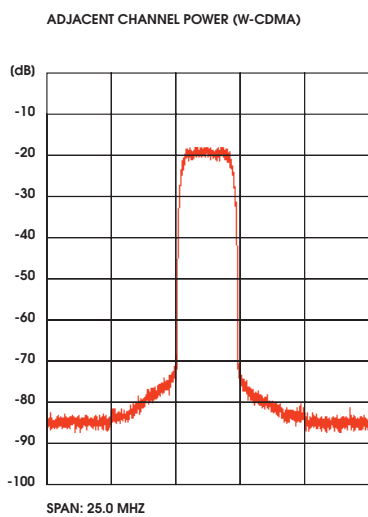

TEST CONDITIONS
5 VDC @ 130 mA, 2140 MHz
Pout = +17 dBm

Tx Power : 16.90 dBm
-10.00 MHz : -64.79 dB
-5.00 MHz : -59.31 dB
5.00 MHz : -60.42 dB
10.00 MHz : -64.88 dB

ACPR vs POWER OUTPUT

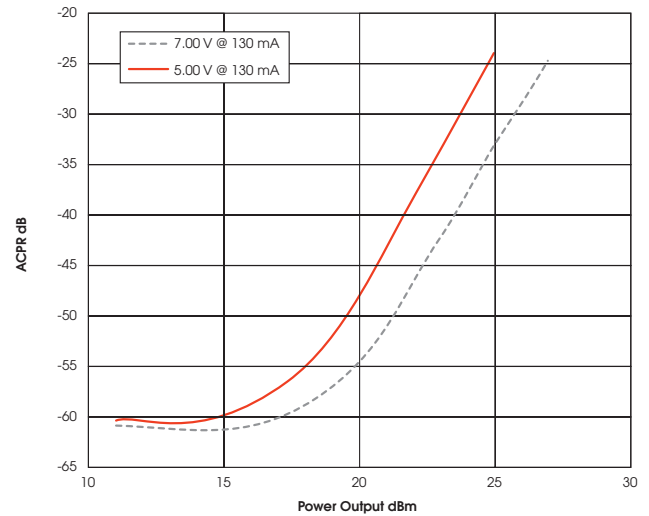

Application notes are available at www.metelics.com.



975 Stewart Drive • Sunnyvale, CA 94085 • www.metelics.com
PH 408.737.8181 • FX 408.733.7645 • sales@metelics.com

© Copyright 2001 MCE Metelics. All rights reserved. Specifications subject to change without notice. Revision date 09.15.01.

MMA701-SOT89

High Linearity Packaged HBT



SMALL SIGNAL S PARAMETERS

Application notes are available at www.metelics.com.

Vcc = 5.00 VDC, Icc = 130 mA

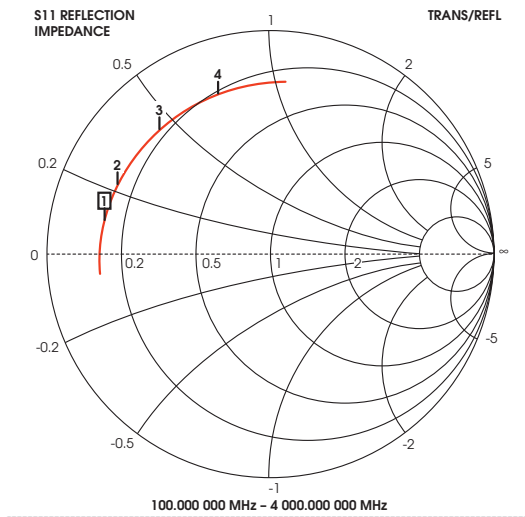

CH 1 - S11

1:	490.000000 MHz	7.241 Ω	4.737 $j\Omega$
2:	997.000000 MHz	7.814 Ω	10.290 $j\Omega$
3:	2.011000000 GHz	9.083 Ω	21.774 $j\Omega$
4:	2.986000000 GHz	11.034 Ω	35.078 $j\Omega$

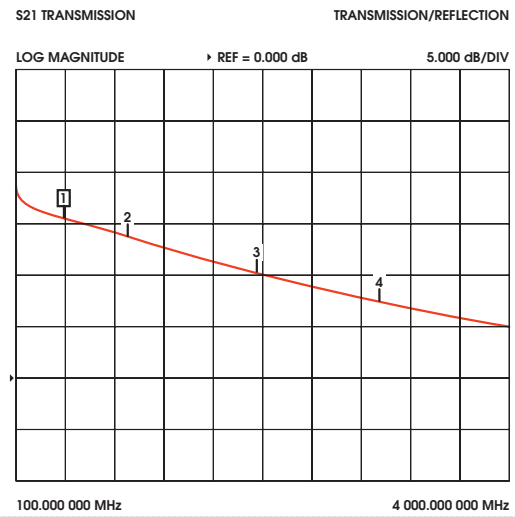

CH 3 - S21

1:	490.000000 MHz	15.534 dB
2:	997.000000 MHz	13.785 dB
3:	2.011000000 GHz	10.228 dB
4:	2.986000000 GHz	7.409 dB

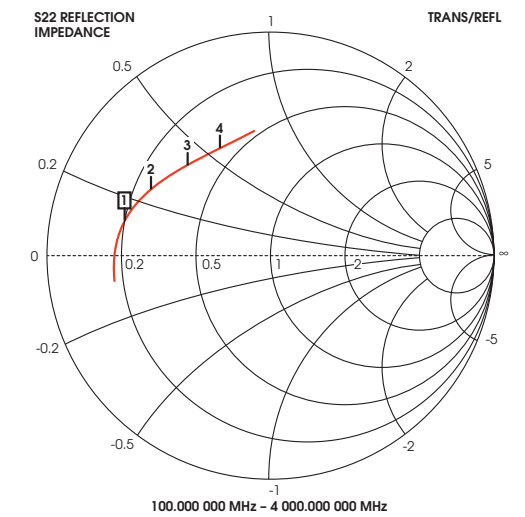

CH 4 - S22

1:	490.000000 MHz	10.468 Ω	6.048 $j\Omega$
2:	997.000000 MHz	13.246 Ω	11.949 $j\Omega$
3:	2.011000000 GHz	17.684 Ω	19.559 $j\Omega$
4:	2.986000000 GHz	21.078 Ω	28.150 $j\Omega$



975 Stewart Drive • Sunnyvale, CA 94085 • www.metelics.com
 PH 408.737.8181 • FX 408.733.7645 • sales@metelics.com

© Copyright 2001 MCE Metelics. All rights reserved. Specifications subject to change without notice. Revision date 09.15.01.

MMA701-SOT89

High Linearity Packaged HBT

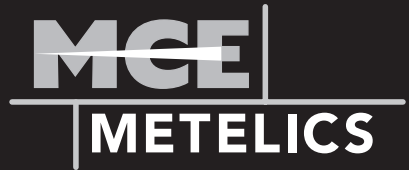

SMALL SIGNAL S PARAMETERS

Application notes are available at www.metelics.com.

V_{cc} = 7.00 VDC, I_{cc} = 130 mA

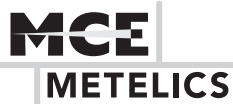
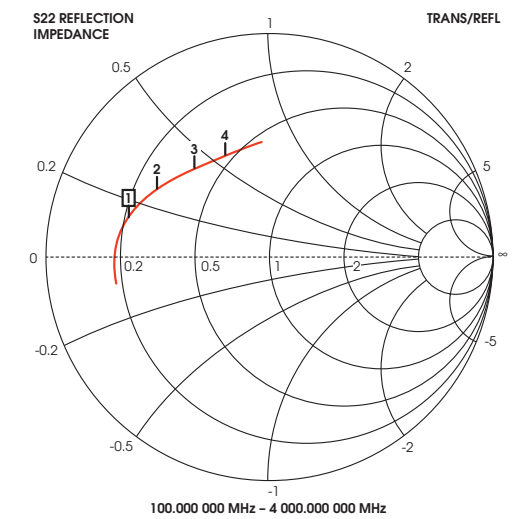
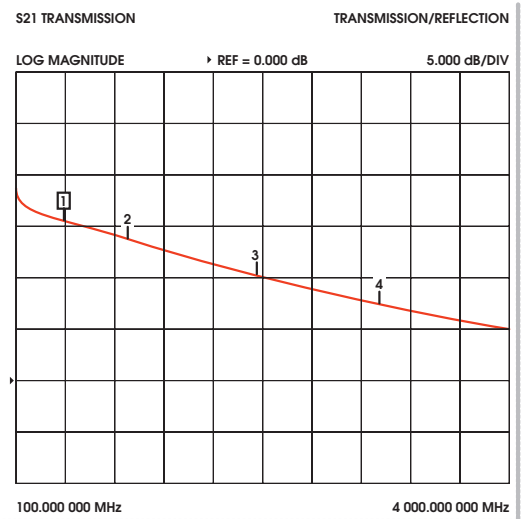
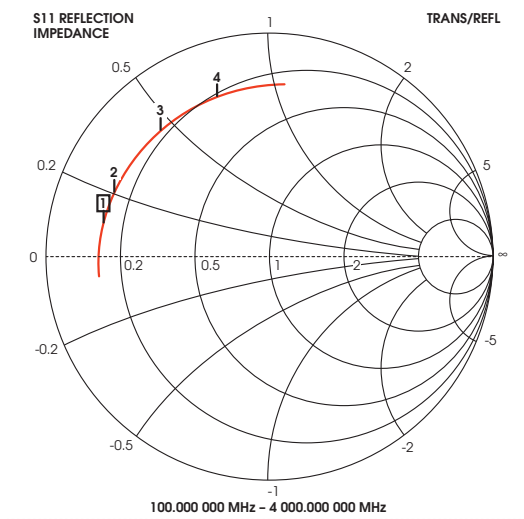

975 Stewart Drive • Sunnyvale, CA 94085 • www.metelics.com
 PH 408.737.8181 • FX 408.733.7645 • sales@metelics.com

© Copyright 2001 MCE Metelics. All rights reserved. Specifications subject to change without notice. Revision date 09.15.01.

MMA701-SOT89

High Linearity Packaged HBT

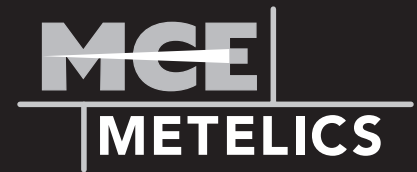

SMALL SIGNAL S PARAMETERS

Application notes are available at www.metelics.com.

Vcc = 7.00 VDC, Icc = 130 mA

Freq. GHz	S11		S21		S12		S22	
	MAG	ANG	MAG	ANG	MAG	ANG	MAG	ANG
0.1000	0.783	-174.97	8.241	136.37	0.041	8.48	0.708	-171.86
0.1295	0.782	-177.60	7.469	139.96	0.041	8.14	0.706	-175.88
0.1590	0.781	-179.82	7.033	141.92	0.041	7.96	0.699	-178.84
0.1885	0.781	178.45	6.764	143.20	0.042	8.30	0.698	178.58
0.2180	0.781	176.92	6.608	143.47	0.042	8.54	0.694	176.35
0.2475	0.780	175.71	6.449	143.47	0.042	9.12	0.693	174.52
0.2770	0.777	174.58	6.338	143.05	0.042	9.60	0.690	172.91
0.3065	0.776	173.55	6.237	142.29	0.042	9.99	0.688	171.55
0.3360	0.775	172.46	6.169	141.03	0.043	10.28	0.680	169.96
0.3655	0.774	171.43	6.078	139.95	0.043	10.69	0.676	168.42
0.3950	0.772	170.57	6.008	138.73	0.044	11.31	0.673	167.08
0.4245	0.775	169.63	5.933	137.45	0.044	11.87	0.674	165.77
0.4540	0.771	168.67	5.879	135.87	0.044	12.26	0.670	164.91
0.4835	0.768	167.93	5.781	134.51	0.045	12.73	0.664	163.83
0.5130	0.769	166.96	5.744	132.91	0.455	13.00	0.658	162.37
0.5425	0.768	166.01	5.677	131.43	0.046	13.46	0.656	161.17
0.5720	0.766	165.39	5.606	130.10	0.046	13.67	0.652	159.97
0.6015	0.765	164.67	5.525	128.41	0.047	14.06	0.651	159.09
0.6310	0.766	163.76	5.463	126.90	0.047	14.57	0.644	158.45
0.6605	0.764	162.63	5.403	125.35	0.047	14.92	0.638	157.41
0.6900	0.765	161.87	5.339	123.76	0.048	15.00	0.632	156.04
0.7195	0.763	161.06	5.280	122.13	0.048	15.21	0.629	155.06
0.7490	0.761	160.40	5.215	120.55	0.049	15.43	0.625	153.80
0.7785	0.759	159.54	5.131	118.89	0.050	15.60	0.625	153.20
0.8080	0.760	158.63	5.092	117.44	0.050	15.71	0.623	152.53
0.8375	0.761	157.84	5.006	115.87	0.051	16.22	0.616	151.77
0.8670	0.762	156.97	4.955	114.33	0.051	16.18	0.611	150.91
0.8965	0.761	156.38	4.898	112.80	0.052	16.31	0.607	149.97
0.9260	0.762	155.37	4.832	111.14	0.052	16.43	0.604	149.16
0.9555	0.757	154.45	4.763	109.47	0.053	16.45	0.601	148.44
0.9850	0.761	153.81	4.722	108.16	0.053	16.50	0.597	147.52
1.0145	0.763	152.94	4.656	106.70	0.054	16.62	0.595	146.78
1.0440	0.760	152.53	4.590	105.25	0.055	16.62	0.593	146.07
1.0735	0.761	151.62	4.536	103.78	0.055	16.92	0.588	145.51
1.1030	0.759	150.93	4.484	102.36	0.056	16.88	0.582	144.88
1.1325	0.758	150.02	4.437	100.94	0.056	16.87	0.578	144.18
1.1620	0.757	149.32	4.385	99.33	0.057	16.84	0.576	142.93
1.1915	0.757	148.34	4.301	98.03	0.058	16.76	0.579	142.26
1.2210	0.761	147.77	4.253	96.78	0.058	16.62	0.576	141.93
1.2505	0.759	146.85	4.208	95.47	0.059	16.57	0.572	141.61
1.2800	0.758	146.25	4.142	93.84	0.059	16.62	0.564	140.88
1.3095	0.756	145.30	4.095	92.48	0.060	16.51	0.563	139.79

Freq. GHz	S11		S21		S12		S22	
	MAG	ANG	MAG	ANG	MAG	ANG	MAG	ANG
1.3390	0.758	144.48	4.039	91.08	0.061	16.44	0.563	139.21
1.3685	0.759	143.85	3.996	89.75	0.061	16.18	0.562	138.41
1.3980	0.758	142.88	3.920	88.50	0.062	16.11	0.560	138.02
1.4275	0.756	142.25	3.881	87.41	0.062	15.90	0.559	137.91
1.4570	0.759	141.40	3.839	85.84	0.063	15.85	0.555	137.13
1.4865	0.757	140.52	3.791	84.43	0.064	15.58	0.549	136.55
1.5160	0.755	139.88	3.734	83.38	0.064	15.52	0.546	135.58
1.5455	0.755	138.97	3.685	82.08	0.065	15.36	0.547	134.85
1.5750	0.756	138.05	3.634	80.75	0.065	15.21	0.548	134.35
1.6045	0.757	137.50	3.613	79.38	0.066	15.00	0.548	133.88
1.6340	0.760	136.48	3.555	78.19	0.066	14.54	0.544	133.65
1.6635	0.761	135.93	3.522	76.76	0.067	14.48	0.542	132.74
1.6930	0.759	135.21	3.482	75.79	0.068	14.12	0.537	132.27
1.7225	0.759	134.17	3.435	74.57	0.068	13.92	0.537	131.82
1.7520	0.758	133.67	3.392	73.26	0.069	13.81	0.535	131.01
1.7815	0.761	132.71	3.360	72.21	0.069	13.48	0.536	130.61
1.8110	0.761	132.06	3.315	70.81	0.070	13.24	0.534	129.75
1.8405	0.759	131.39	3.266	69.69	0.071	12.97	0.534	129.23
1.8700	0.761	130.53	3.240	68.45	0.071	12.69	0.531	128.83
1.8995	0.763	129.68	3.206	67.47	0.071	12.44	0.530	128.31
1.9290	0.761	128.78	3.170	66.45	0.072	12.14	0.527	127.61
1.9585	0.762	128.01	3.126	65.03	0.073	11.85	0.527	126.91
1.9880	0.761	127.71	3.075	63.91	0.073	11.38	0.527	126.21
2.0175	0.760	126.69	3.054	62.88	0.074	11.05	0.526	125.97
2.0470	0.763	125.55	3.015	61.73	0.075	10.76	0.525	125.56
2.0765	0.764	124.73	2.983	60.36	0.075	10.35	0.522	124.91
2.1060	0.762	123.98	2.933	59.57	0.076	10.01	0.522	124.31
2.1355	0.762	123.23	2.909	58.17	0.076	9.78	0.520	123.52
2.1650	0.762	122.44	2.880	56.95	0.077	9.40	0.521	123.06
2.1945	0.766	121.64	2.840	55.99	0.077	9.04	0.520	122.47
2.2240	0.765	121.04	2.820	55.06	0.078	8.71	0.519	122.02
2.2535	0.766	120.05	2.783	53.72	0.078	8.27	0.519	121.37
2.2830	0.770	119.38	2.737	52.96	0.079	7.91	0.518	120.84
2.3125	0.770	118.59	2.716	51.91	0.079	7.49	0.518	120.00
2.3420	0.766	117.99	2.686	50.77	0.080	7.12	0.519	119.62
2.3715	0.768	116.59	2.654	49.77	0.081	6.63	0.519	119.03
2.4010	0.765	116.51	2.634	48.60	0.081	6.21	0.516	118.49
2.4305	0.769	115.86	2.602	47.78	0.082	5.89	0.518	117.98
2.4600	0.766	115.09	2.575	46.38	0.082	5.55	0.515	117.24
2.4895	0.767	113.99	2.555	45.26	0.083	5.11	0.519	116.71
2.5190	0.771	113.30	2.525	44.51	0.083	4.63	0.517	116.29
2.5485	0.773	112.54	2.496	43.45	0.083	4.25	0.515	115.86

MMA701-SOT89

High Linearity Packaged HBT



SMALL SIGNAL S PARAMETERS

Application notes are available at www.metelics.com.

V_{cc} = 7.00 VDC, I_{cc} = 130 mA

Freq. GHz	S11		S21		S12		S22	
	MAG	ANG	MAG	ANG	MAG	ANG	MAG	ANG
2.5780	0.769	112.01	2.479	42.13	0.084	3.68	0.515	115.10
2.6075	0.774	110.82	2.456	41.35	0.084	3.18	0.515	114.50
2.6370	0.768	110.17	2.417	40.44	0.085	2.76	0.516	113.88
2.6665	0.770	109.33	2.398	39.54	0.085	2.31	0.518	113.32
2.6960	0.773	108.68	2.373	38.33	0.086	2.05	0.518	113.03
2.7255	0.776	107.85	2.343	37.46	0.086	1.57	0.515	112.55
2.7550	0.774	107.11	2.327	36.34	0.086	0.98	0.515	111.65
2.7845	0.768	106.09	2.295	35.33	0.087	0.55	0.516	110.90
2.8140	0.769	105.53	2.270	34.55	0.087	0.11	0.518	110.09
2.8435	0.770	104.61	2.252	33.68	0.088	-0.38	0.520	109.56
2.8730	0.779	103.80	2.244	32.58	0.088	-0.88	0.519	109.03
2.9025	0.778	103.20	2.211	31.43	0.089	-1.26	0.516	108.64
2.9320	0.776	102.71	2.195	30.36	0.089	-1.76	0.520	107.71
2.9615	0.774	101.82	2.177	29.67	0.089	-2.33	0.515	106.89
2.9910	0.776	100.74	2.147	28.46	0.090	-2.64	0.518	106.09
3.0205	0.777	100.01	2.125	27.50	0.090	-3.24	0.522	105.67
3.0500	0.775	99.55	2.105	26.78	0.091	-3.78	0.521	105.39
3.0795	0.780	99.07	2.090	25.97	0.091	-4.32	0.522	104.96
3.1090	0.777	97.84	2.067	24.80	0.091	-4.71	0.522	104.37
3.1385	0.779	97.02	2.048	23.58	0.092	-5.11	0.520	103.55
3.1680	0.779	96.43	2.029	22.99	0.092	-5.81	0.520	102.61
3.1975	0.780	95.54	2.014	22.08	0.092	-6.34	0.521	101.82
3.2270	0.784	94.66	1.988	20.99	0.092	-6.71	0.525	101.04
3.2565	0.785	94.11	1.968	20.19	0.093	-7.30	0.528	100.66
3.2860	0.784	93.59	1.952	19.18	0.093	-7.95	0.528	100.40
3.3155	0.786	92.39	1.939	18.10	0.093	-8.32	0.526	99.95
3.3450	0.783	91.54	1.926	16.97	0.094	-8.76	0.524	98.94
3.3745	0.787	90.82	1.900	16.32	0.094	-9.22	0.526	97.87
3.4040	0.788	90.03	1.889	15.38	0.094	-9.80	0.530	97.02
3.4335	0.788	89.33	1.865	14.49	0.094	-10.36	0.533	96.49
3.4630	0.787	88.64	1.841	13.42	0.095	-10.83	0.535	96.45
3.4925	0.791	88.04	1.832	12.54	0.095	-11.50	0.535	95.84
3.5220	0.789	87.40	1.821	11.69	0.095	-12.14	0.531	95.18
3.5515	0.793	86.40	1.803	10.59	0.096	-12.49	0.530	94.01
3.5810	0.792	85.74	1.781	9.76	0.096	-13.12	0.535	93.03
3.6105	0.795	84.98	1.768	9.04	0.096	-13.65	0.537	92.53
3.6400	0.798	84.57	1.755	8.10	0.096	-14.11	0.540	92.07
3.6695	0.798	83.82	1.736	6.94	0.096	-14.75	0.541	91.61
3.6990	0.797	82.69	1.723	6.14	0.097	-15.41	0.540	90.98
3.7285	0.796	82.01	1.715	5.33	0.097	-16.05	0.537	90.26
3.7580	0.801	81.24	1.695	4.47	0.097	-16.44	0.541	89.30
3.7875	0.806	80.56	1.675	3.31	0.097	-17.08	0.544	88.80

Freq. GHz	S11		S21		S12		S22	
	MAG	ANG	MAG	ANG	MAG	ANG	MAG	ANG
3.8170	0.804	80.08	1.661	2.39	0.097	-17.66	0.547	88.31
3.8465	0.801	79.20	1.643	1.86	0.097	-18.12	0.547	87.69
3.8760	0.801	78.32	1.631	0.71	0.097	-18.73	0.548	87.14
3.9055	0.806	77.61	1.618	-0.03	0.097	-19.23	0.549	86.54
3.9350	0.808	76.88	1.598	-0.90	0.098	-19.96	0.551	85.69
3.9645	0.812	76.35	1.586	-1.70	0.097	-20.66	0.551	84.91
3.9940	0.809	75.91	1.571	-2.59	0.098	-21.18	0.551	84.38
4.0235	0.809	74.87	1.561	-3.49	0.098	-21.77	0.557	83.88
4.0530	0.810	74.07	1.549	-4.38	0.098	-22.44	0.556	83.42
4.0825	0.814	73.16	1.536	-5.26	0.098	-22.84	0.559	82.64
4.1120	0.816	72.51	1.518	-6.12	0.098	-23.41	0.556	81.84
4.1415	0.814	72.19	1.501	-6.95	0.097	-24.09	0.559	81.27
4.1710	0.815	71.64	1.488	-7.68	0.098	-24.60	0.560	80.61
4.2005	0.814	70.82	1.480	-8.91	0.097	-25.18	0.562	79.97
4.2300	0.817	69.92	1.466	-9.33	0.098	-25.70	0.564	79.64
4.2595	0.820	68.99	1.453	-10.39	0.098	-26.32	0.564	79.02
4.2890	0.820	68.41	1.443	-11.43	0.097	-26.82	0.566	78.31
4.3185	0.822	67.82	1.430	-12.17	0.097	-27.19	0.568	77.80
4.3480	0.824	67.30	1.418	-12.94	0.097	-27.98	0.568	77.23
4.3775	0.823	66.48	1.410	-13.88	0.097	-28.60	0.571	76.55
4.4070	0.823	65.78	1.397	-14.84	0.097	-29.04	0.575	75.76
4.4365	0.823	65.21	1.384	-15.74	0.097	-29.57	0.577	75.27
4.4660	0.827	64.29	1.374	-16.57	0.097	-30.15	0.580	74.74
4.4955	0.829	63.55	1.358	-17.29	0.097	-30.75	0.580	74.25
4.5250	0.832	62.93	1.350	-18.51	0.097	-31.23	0.581	73.63
4.5545	0.831	62.40	1.333	-19.03	0.097	-31.93	0.580	73.02
4.5840	0.832	61.65	1.326	-20.10	0.096	-32.49	0.583	72.21
4.6135	0.832	60.89	1.313	-21.01	0.096	-32.91	0.589	71.66
4.6430	0.835	60.40	1.304	-22.20	0.097	-33.55	0.592	71.12
4.6725	0.836	59.63	1.288	-22.69	0.096	-34.26	0.593	70.89
4.7020	0.840	59.15	1.279	-23.46	0.095	-34.81	0.592	70.26
4.7315	0.841	58.48	1.269	-24.46	0.095	-35.27	0.593	69.53
4.7610	0.841	57.96	1.255	-25.35	0.095	-36.02	0.596	68.78
4.7905	0.840	57.00	1.238	-26.02	0.095	-36.48	0.597	68.10
4.8200	0.842	56.26	1.227	-26.92	0.094	-37.00	0.601	67.62
4.8495	0.852	55.70	1.220	-27.77	0.094	-37.90	0.602	67.10
4.8790	0.845	55.35	1.208	-28.42	0.094	-38.17	0.605	66.49
4.9085	0.845	54.75	1.196	-29.30	0.093	-38.36	0.606	66.04
4.9380	0.846	53.94	1.187	-30.12	0.094	-39.03	0.608	65.45
4.9675	0.847	53.07	1.174	-30.87	0.094	-40.08	0.610	64.84
4.9970	0.849	52.56	1.162	-31.91	0.094	-40.20	0.612	63.84
5.0265	0.852	52.13	1.157	-32.63	0.092	-41.03	0.616	63.69



975 Stewart Drive • Sunnyvale, CA 94085 • www.metelics.com
 PH 408.737.8181 • FX 408.733.7645 • sales@metelics.com

© Copyright 2001 MCE Metelics. All rights reserved. Specifications subject to change without notice. Revision date 09.15.01.

MMA701-SOT89

High Linearity Packaged HBT

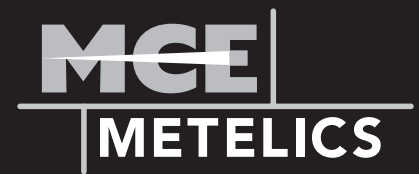

SMALL SIGNAL S PARAMETERS

Application notes are available at www.metelics.com.

Vcc = 7.00 VDC, Icc = 130 mA

Freq. GHz	S11		S21		S12		S22	
	MAG	ANG	MAG	ANG	MAG	ANG	MAG	ANG
5.0560	0.855	51.87	1.146	-33.45	0.092	-41.14	0.617	63.06
5.0855	0.852	51.14	1.131	-34.17	0.092	-41.83	0.622	62.59
5.1150	0.849	50.02	1.123	-34.92	0.092	-42.47	0.623	62.07
5.1445	0.852	49.44	1.110	-35.83	0.092	-42.86	0.622	61.46
5.1740	0.857	48.89	1.099	-36.59	0.092	-43.68	0.626	60.90
5.2035	0.858	48.38	1.091	-37.37	0.091	-43.78	0.627	60.29
5.2330	0.860	47.81	1.082	-38.02	0.092	-44.63	0.631	59.83
5.2625	0.857	47.34	1.067	-38.62	0.091	-45.24	0.632	59.19
5.2920	0.856	46.51	1.059	-39.58	0.091	-45.39	0.636	58.68
5.3215	0.862	45.80	1.052	-40.23	0.090	-45.99	0.636	58.14
5.3510	0.862	45.23	1.044	-41.03	0.090	-46.38	0.638	57.94
5.3805	0.863	44.95	1.026	-41.81	0.089	-47.10	0.638	57.43
5.4100	0.864	44.35	1.023	-42.50	0.090	-47.52	0.641	56.98
5.4395	0.864	44.08	1.011	-43.35	0.089	-47.99	0.642	56.39
5.4690	0.865	43.25	1.001	-43.97	0.088	-48.50	0.647	55.75
5.4985	0.862	42.74	0.989	-44.89	0.088	-48.92	0.648	55.28
5.5280	0.864	42.27	0.985	-45.35	0.088	-49.21	0.649	54.91
5.5575	0.865	41.54	0.978	-46.54	0.088	-50.07	0.651	54.51
5.5870	0.862	41.00	0.962	-46.85	0.087	-50.24	0.652	54.02
5.6165	0.865	40.53	0.958	-47.63	0.087	-50.62	0.652	53.44
5.6460	0.867	40.14	0.941	-48.39	0.087	-50.82	0.656	52.76
5.6755	0.867	39.44	0.939	-49.02	0.086	-51.39	0.657	52.26
5.7050	0.864	38.76	0.930	-49.73	0.087	-52.40	0.661	51.93
5.7345	0.869	38.17	0.920	-50.26	0.087	-53.04	0.662	51.57
5.7640	0.867	37.55	0.915	-51.37	0.087	-53.59	0.661	51.20
5.7935	0.867	37.17	0.904	-52.06	0.085	-53.49	0.663	50.61
5.8230	0.869	36.77	0.898	-52.68	0.086	-54.47	0.663	50.03
5.8525	0.869	36.31	0.890	-53.39	0.085	-54.57	0.666	49.37
5.8820	0.867	35.66	0.883	-53.94	0.085	-54.97	0.670	48.91
5.9115	0.871	35.11	0.874	-54.66	0.085	-55.76	0.672	48.67
5.9410	0.871	34.43	0.866	-54.92	0.084	-56.20	0.674	48.30
5.9705	0.871	34.33	0.857	-56.08	0.084	-56.42	0.672	47.79
6.0000	0.873	33.92	0.851	-56.63	0.084	-57.32	0.675	47.22

MMA701-SOT89

High Linearity Packaged HBT

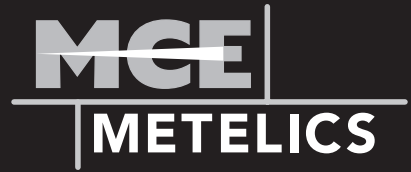

OUTLINE DRAWING

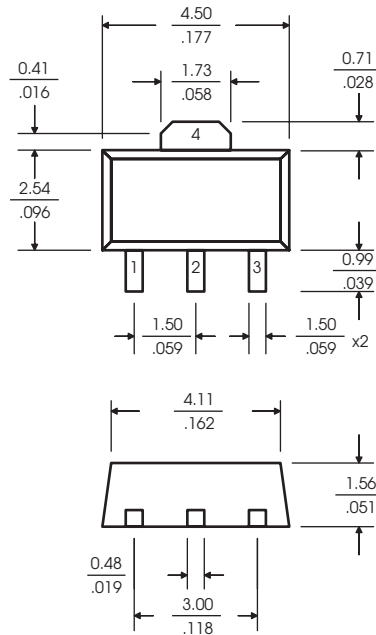

Function	Pin Number
Input/Base	1
DC/RF Ground	2
Output/Collector	3
DC/RF Ground	4

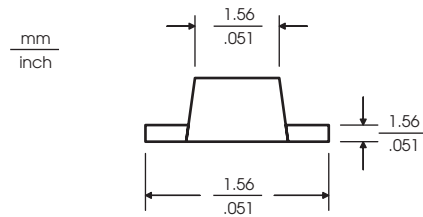

MOUNTING CONFIGURATION

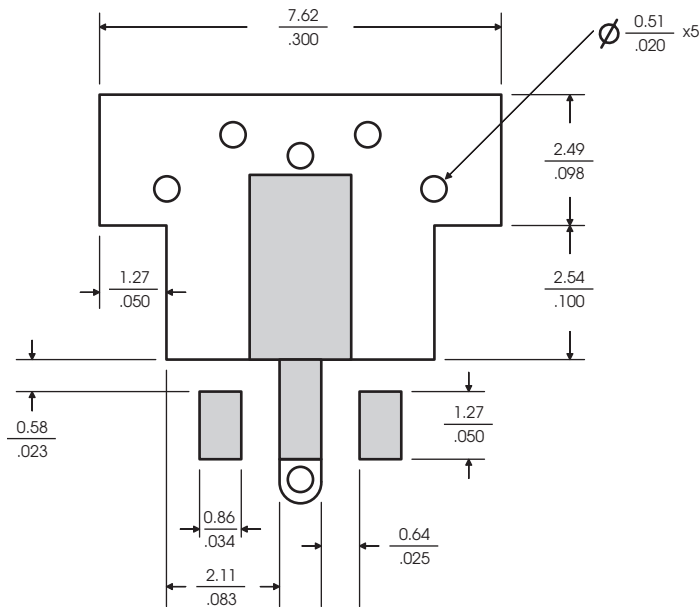

LAND PATTERN

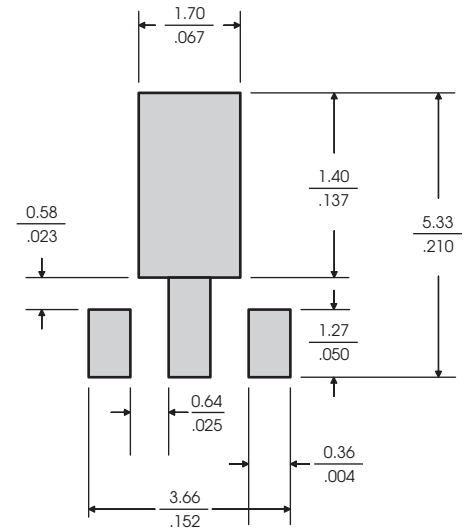

ORDERING INFORMATION

Bulk Part Number: MMA701-SOT89
 Tape and Reel Part Number: MMA701-SOT89TR
 Evaluation Board: MMA701-SOT89EB, Specify Frequency

Application notes are available
 at www.metelics.com.



975 Stewart Drive • Sunnyvale, CA 94085 • www.metelics.com
 PH 408.737.8181 • FX 408.733.7645 • sales@metelics.com

© Copyright 2001 MCE Metelics. All rights reserved. Specifications subject to change without notice. Revision date 09.15.01.